

Paper Jams

This topic includes:

- "Jam at the Exit Cover" on page 4-3
- "Jam at the Front Cover" on page 4-7
- "Jam at Tray 1" on page 4-12
- "Jam at Tray 2, 3, or 4" on page 4-13

For safety information, go to [Reference/Troubleshooting/User Safety](#) on the *User Documentation CD-ROM*.

Jam at the Exit Cover

Follow these steps to clear the jam.

1. Open the exit cover.

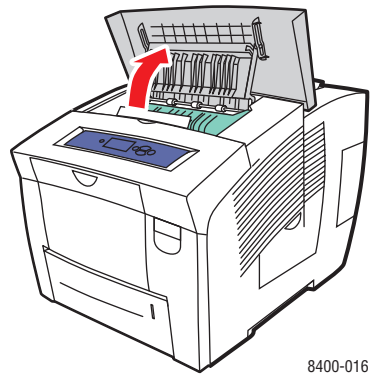

2. Pull the jammed paper slowly out of the printer. Verify that any torn pieces of paper are removed.

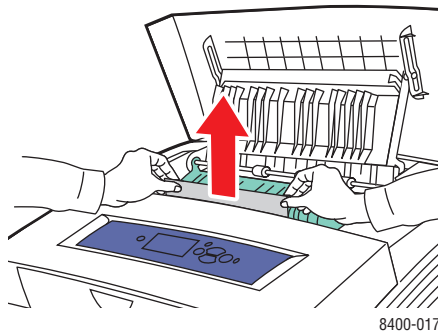

3. If you did not find paper in Step 2, lift up the green paper guides.

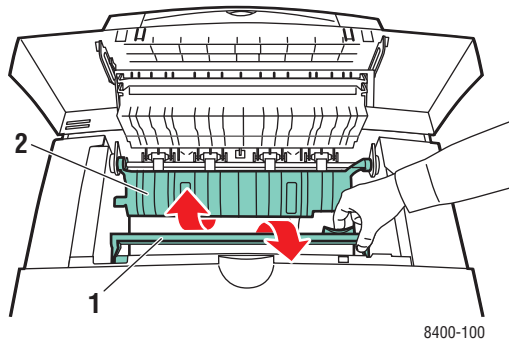

4. Remove jammed paper.

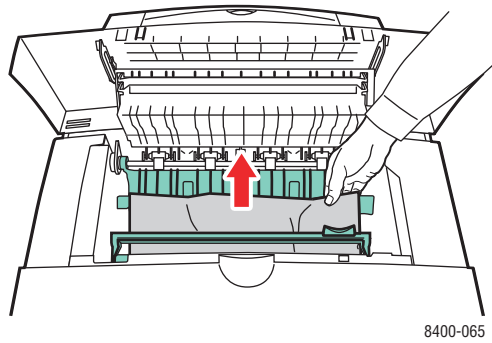

5. Close the exit cover.

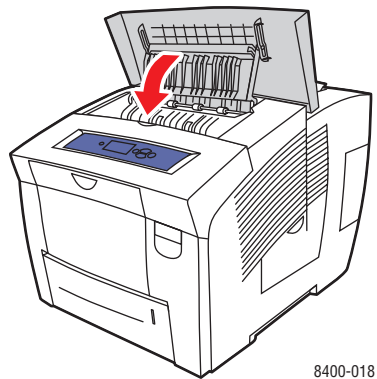

6. If you did not find paper in Steps 2–4, follow these steps.
 - a. Pull up the latch on the front of the printer to open the front cover.

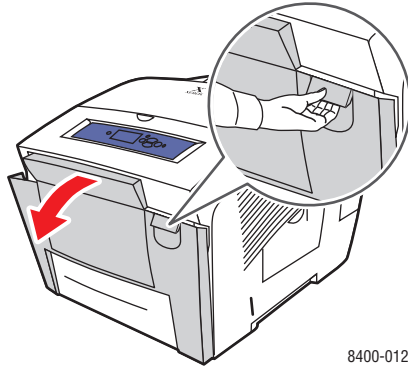

- b. Pull the jammed paper slowly out of the printer. Verify that any torn pieces of paper are removed.

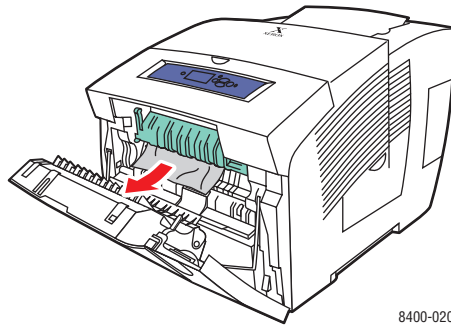

- c. Close the front cover.

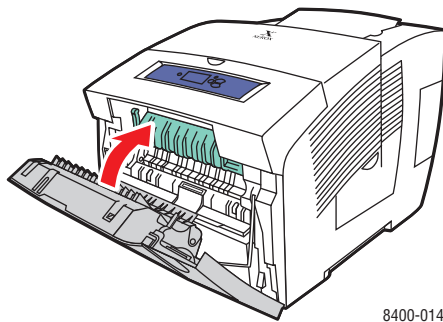

7. If you did not find jammed paper in the previous steps, follow these steps.
 - a. Pull all the trays completely out of the printer and remove jammed paper.

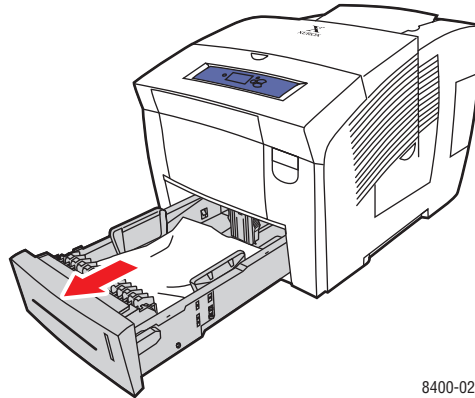

- b. Pull the jammed paper slowly out of the printer. Verify that any torn pieces of paper are removed.

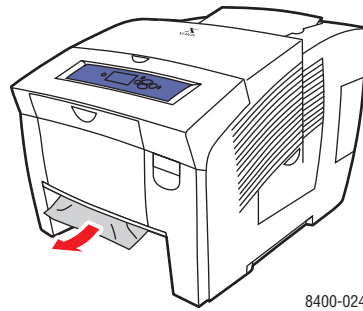

- c. Replace all trays and push each one completely to the back of the printer.

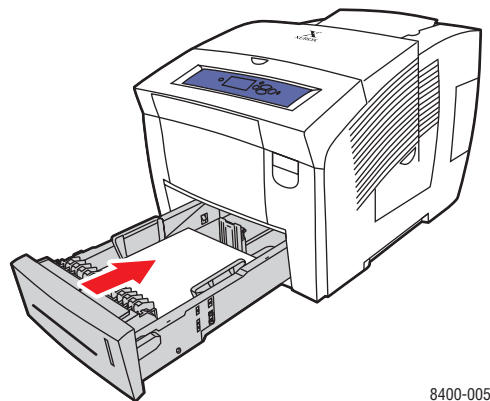

Jam at the Front Cover

Follow these steps to clear the jam.

1. Pull up the latch on the front of the printer to open the front cover.

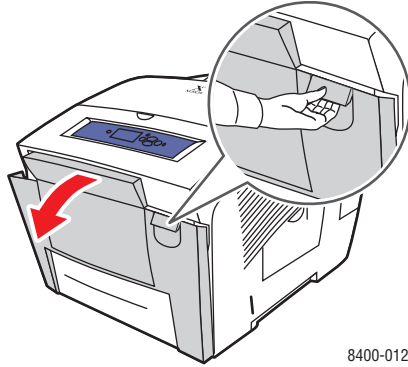

8400-012

2. Lift up the green paper guides.

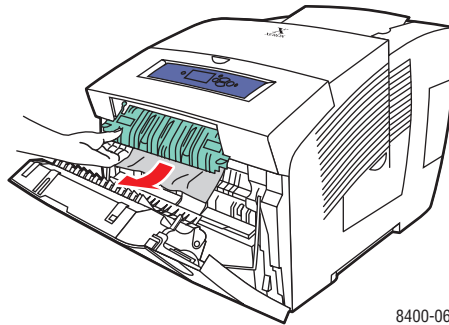

8400-061

3. Pull the jammed paper slowly out of the printer. Verify that any torn pieces of paper are removed.

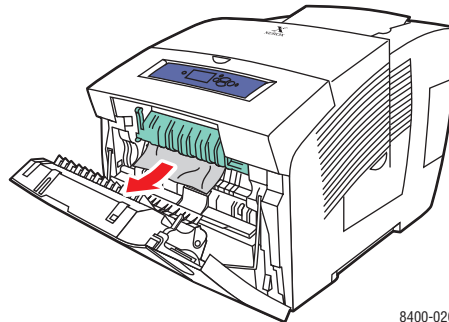

8400-020

4. Snap the green paper guide into place and close the front cover.

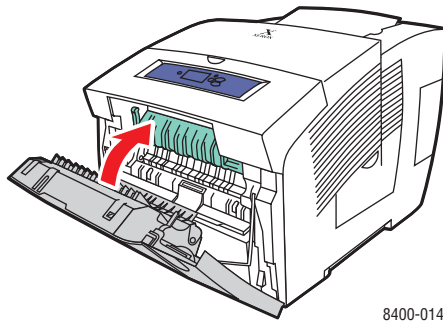

8400-014

5. If you did not find paper in Step 2, follow these steps.
 - a. Open the exit cover.

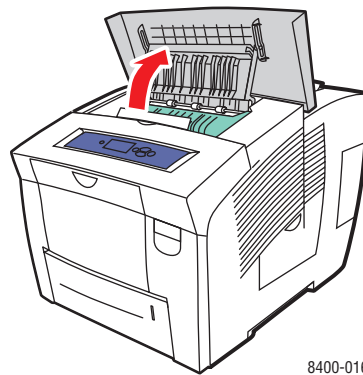

8400-016

- b. Pull the jammed paper slowly out of the printer. Verify that any torn pieces of paper are removed.

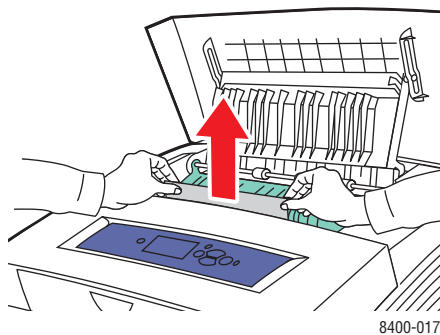

8400-017

- c. Lift up the green paper guides.

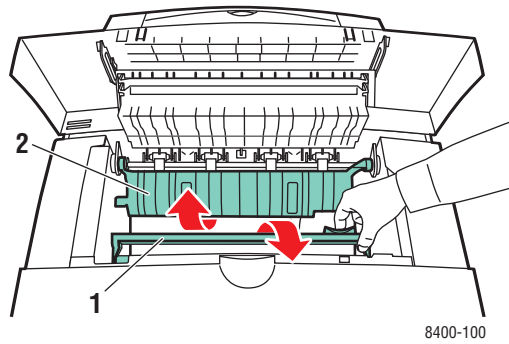

- d. Remove jammed paper.

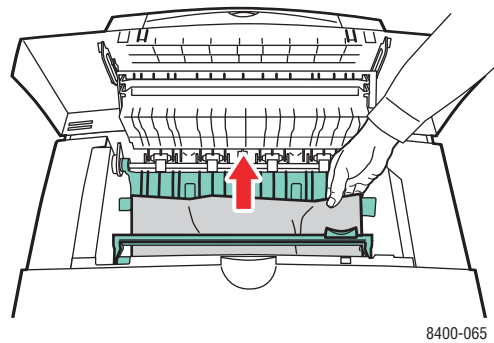

- e. Close the exit cover.

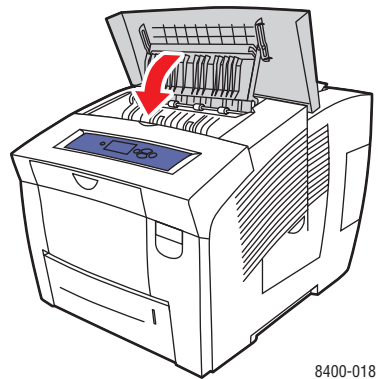

- 6. If you did not find jammed paper in the previous steps, follow these steps.

- a.** Pull all the trays completely out of the printer and removed jammed paper.

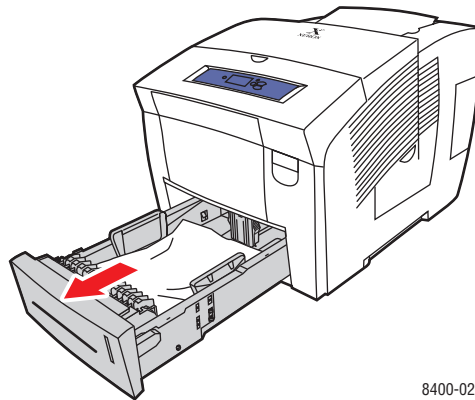

8400-028

- b.** Pull the jammed paper slowly out of the printer. Verify that any torn pieces of paper are removed.

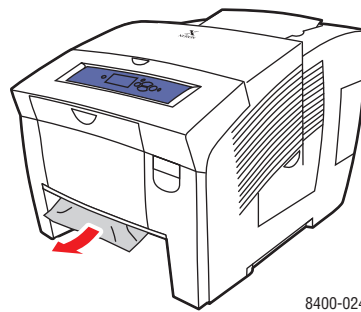

8400-024

- c.** Replace all trays and push each one completely to the back of the printer.

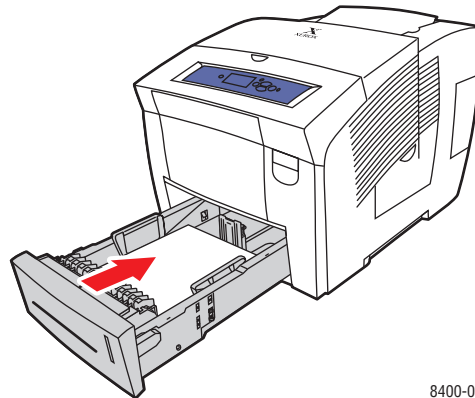

8400-005

Note

Use only the approved paper type, weight, and size for the tray. Custom size paper can be used in Tray 1 only.

For additional information, go to www.phaserSMART.com.

Jam at Tray 1

Follow these steps to clear the jam.

1. Remove all of the paper from Tray 1. Verify that any torn or pieces of paper are removed.

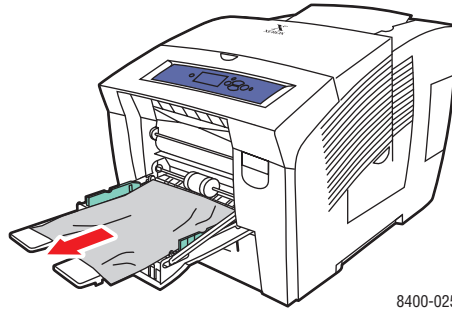

8400-025

2. Load the paper and push it completely to the back of the tray.
3. Press the side guides against the paper.

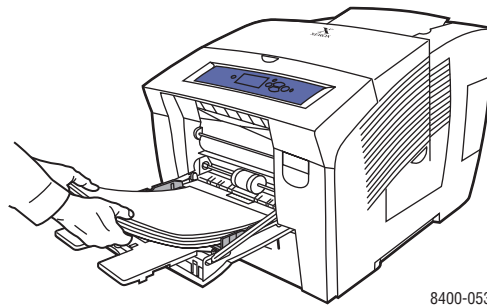

8400-053

For additional information, go to www.phaserSMART.com.

Jam at Tray 2, 3, or 4

Follow these steps to clear the jam for the tray specified on the front panel.

1. Pull the tray specified on the front panel completely out of the printer.

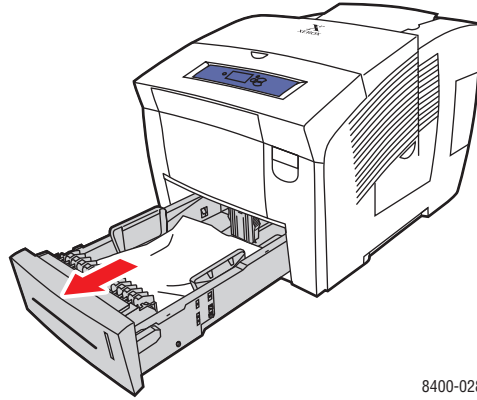

8400-028

2. Remove the top sheet from the tray.

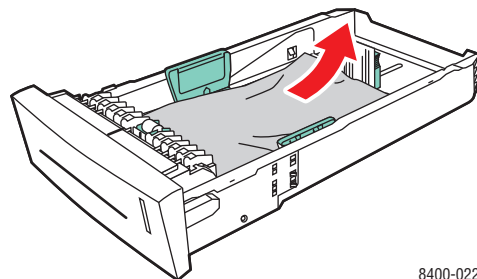

8400-022

3. Verify that the paper is loaded correctly in the tray. Adjust the length and side paper guides.
 - a. Press the sides of the length guide and slide the guide until the arrows on the guide matches the appropriate paper size and clicks into place.
 - b. Slide the side guides until the arrows on the guides match the appropriate paper size and the guides click into place.

Note

When the guides are correctly adjusted, there may be a small space between the paper and the paper guides.

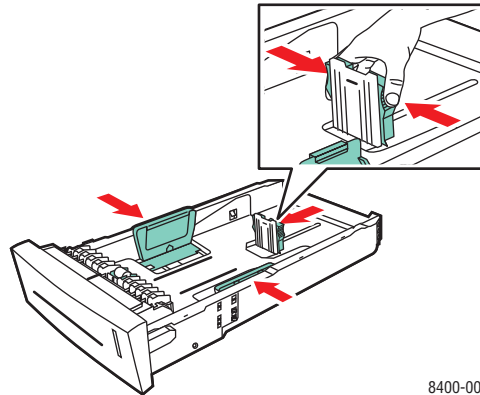

8400-004

4. Remove jammed paper inside the printer tray slot. Confirm that any torn pieces of paper are removed.

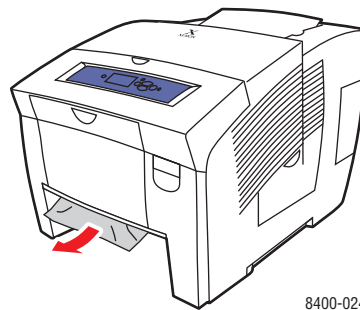

8400-024

5. If you did not find jammed paper in Step 4, follow these steps.
 - a. Pull up the latch on the front of the printer to open the front cover.

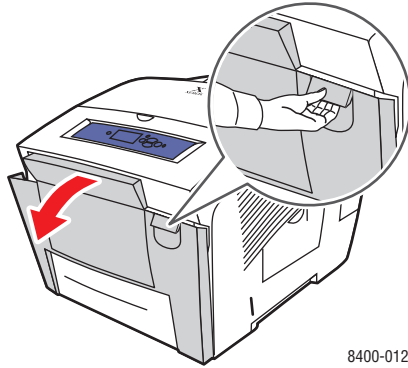

- b. Pull the jammed paper slowly out of the printer. Confirm that any torn pieces of paper are removed.

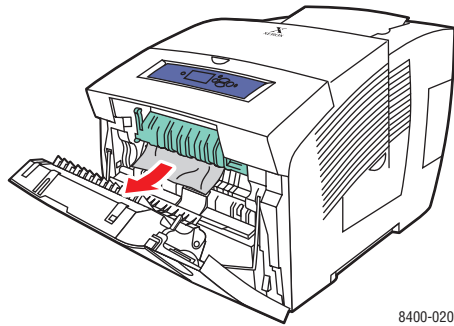

- c. Close the front cover.

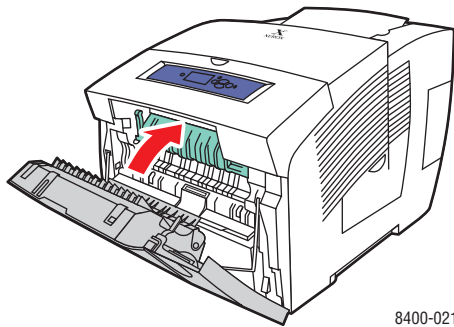

6. Insert the tray into the tray slot and push it completely to the back of the printer.

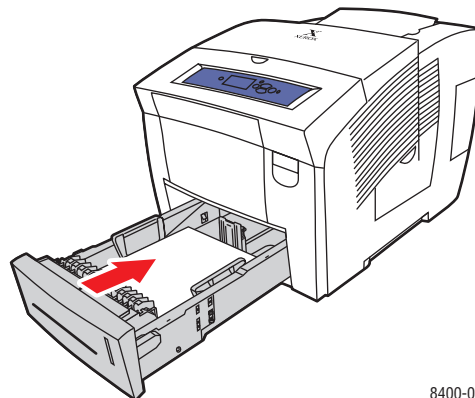

8400-005

For additional information, go to www.phaserSMART.com.